

## Spring Plungers

**Stainless Steel / Brass / Plastic,  
Ball Stainless Steel / Plastic, Press-On Type**

### SPECIFICATION

#### Types

- Type **NI**: Stainless steel, standard spring load
- Type **NIL**: Stainless steel, light spring load
- Type **NIS**: Stainless steel, high spring load
- Type **MS**: Housing brass, ball stainless steel, standard spring load
- Type **KU**: Housing plastic, ball stainless steel, standard spring load
- Type **KD**: Housing plastic, ball plastic, standard spring load

Types NI / NIL / NIS

- Housing  
Stainless steel AISI 305  
Sheet-metal
- Ball  
Stainless steel AISI 420C  
Hardened

Identification

- Type NIL: Housing with 1 longitudinal marking
- Type NIS: Housing with 2 longitudinal markings

Type MS

- Housing  
Brass, turned
- Ball  
Stainless steel AISI 420C, hardened

Type KU

- Housing  
Plastic, polyacetal (POM)  
Operating temperature up to 50 °C  
Blue
- Ball  
Stainless steel AISI 420C, hardened

Type KD

- Housing  
Plastic, polyacetal (POM)  
Operating temperature up to 50 °C  
Blue
- Ball  
Plastic, polyacetal (POM)  
Operating temperature up to 50 °C  
White

Pressure spring

Stainless steel AISI 631



### INFORMATION

Spring plungers GN 614 are used as detents as well as for push-on and push-off applications and ejectors.  
A tolerance of H7 for the location hole of d<sub>1</sub> is recommended.

### TECHNICAL INFORMATION

- ISO Fundamental Tolerances (see page A26)
- Plastic Characteristics (see page A2)
- Stainless Steel Characteristics (see page A21)

Type NI

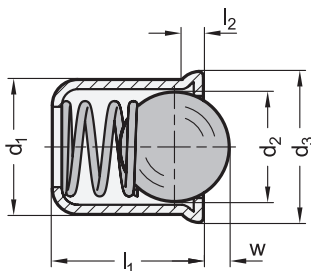

Type MS / KU / KD

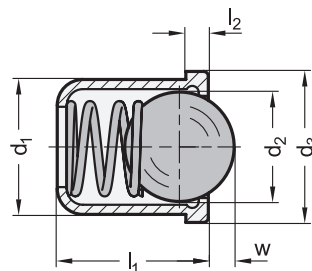

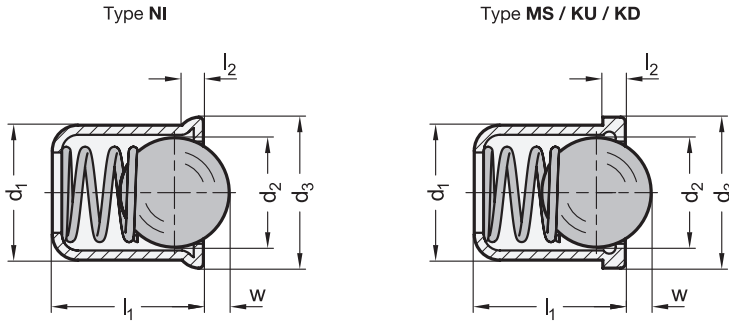

### GN 614-NI STAINLESS STEEL

Description	d1 +0.1	d2	d3	l1 ≈ l2 ≈	w	Spring load in N ≈ initial	Spring load in N ≈ end	⚖️	
GN 614-3-NI	3	2.4	3.5	4	0.6	0.7	1.8	3.5	1
GN 614-4-NI	4	3	4.6	5	0.9	1	2.5	6	2
GN 614-5-NI	5	4	5.6	6	0.9	1.4	3	6.5	3
GN 614-6-NI	6	5	6.5	7	1	1.8	5.5	11.5	4
GN 614-8-NI	8	6.5	8.5	9	1.1	2.4	7	12.5	5
GN 614-10-NI	10	8.5	11	13	1.5	3.3	8.5	18.5	6
GN 614-12-NI	12	10	13	16	2.3	4	12	26.5	7

### GN 614-NIL STAINLESS STEEL

Description	d1 +0.1	d2	d3	l1 ≈ l2 ≈	w	Spring load in N ≈ initial	Spring load in N ≈ end	⚖️	
GN 614-3-NIL	3	2.4	3.5	4	0.6	0.7	0.4	1.3	1
GN 614-4-NIL	4	3	4.6	5	0.9	1	0.5	1	2
GN 614-5-NIL	5	4	5.6	6	0.9	1.4	0.5	4.7	3
GN 614-6-NIL	6	5	6.5	7	1	1.8	2.3	6.5	4
GN 614-8-NIL	8	6.5	8.5	9	1.1	2.4	4	9	5
GN 614-10-NIL	10	8.5	11	13	1.5	3.3	3.9	10	6
GN 614-12-NIL	12	10	13	16	2.3	4	6.2	14.6	7

### GN 614-NIS STAINLESS STEEL

Description	d1 +0.1	d2	d3	l1 ≈ l2 ≈	w	Spring load in N ≈ initial	Spring load in N ≈ end	⚖️	
GN 614-3-NIS	3	2.4	3.5	4	0.6	0.7	2.4	5.5	1
GN 614-4-NIS	4	3	4.6	5	0.9	1	5	10.4	1
GN 614-5-NIS	5	4	5.6	6	0.9	1.4	6	12	2
GN 614-6-NIS	6	5	6.5	7	1	1.8	7.3	19	3
GN 614-8-NIS	8	6.5	8.5	9	1.1	2.4	11	25	4
GN 614-10-NIS	10	8.5	11	13	1.5	3.3	17	37	5
GN 614-12-NIS	12	10	13	16	2.3	4	28	57	6

### GN 614-MS

Description	d1 +0.1	d2	d3	l1 ≈ l2 ±0.1	w	Spring load in N ≈ initial	Spring load in N ≈ end	⚖️	
GN 614-3-MS	3	2.4	3.6	4	0.6	0.6	1.8	3.5	1
GN 614-4-MS	4	3	4.6	5	1	0.8	2.5	6	2
GN 614-5-MS	5	4	5.6	6	1	1	3	6.5	3
GN 614-6-MS	6	5	6.5	7	1	1.6	5.5	11.5	4
GN 614-8-MS	8	6.5	8.5	9	1	1.9	7	12.5	5

### GN 614-KU

Description	d1 +0.1	d2	d3	l1 ≈ l2 ±0.1	w	Spring load in N ≈ initial	Spring load in N ≈ end	⚖️	
GN 614-3-KU	3	2	3.6	4	0.6	0.55	1.7	3.5	1
GN 614-4-KU	4	3	4.6	5	1	0.8	3	6.5	2
GN 614-5-KU	5	4	5.6	6	1	1	6	9.4	3
GN 614-6-KU	6	5	6.5	7	1	1.6	6.2	12.6	4
GN 614-8-KU	8	6.5	8.5	9	1	1.9	10	20.4	5
GN 614-10-KU	10	8	11	13.5	1.5	2.4	11.9	22.3	6
GN 614-12-KU	12	10	13	16	1.5	3.3	14	25	7

### GN 614-KD

Description	d1 +0.1	d2	d3	l1 ≈ l2 ±0.1	w	Spring load in N ≈ initial	Spring load in N ≈ end	⚖️	
GN 614-4-KD	4	3	4.6	5	1	0.8	3	6.5	1
GN 614-5-KD	5	4	5.6	6	1	1	6	9.4	2
GN 614-6-KD	6	5	6.5	7	1	1.6	6.2	12.6	3
GN 614-8-KD	8	6.5	8.5	9	1	1.9	10	20.4	4
GN 614-10-KD	10	8	11	13.5	1.5	2.4	11.9	22.3	5
GN 614-12-KD	12	10	13	16	1.5	3.3	14	25	6

